

Frame Styles

Key's **vibratory conveyors** can be configured with many cost-effective frame styles to solve the toughest application and line layout challenges.

Typical design features include:

- Tubular-style frame construction
- Large open area below and ahead of discharge
- Out-of-the-way drive system, below infeed area
- Infeed flexibility



Partial Cantilever Frame

- Ideal for feed shakers

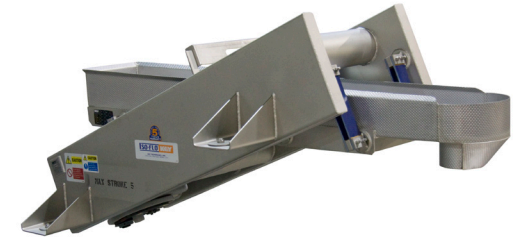

Diagonal Frame

- Ideal for scale-feed shakers
- Strong, cost-effective design for relatively short beds



Below Bed Frame

- Conventional design; frame and drive are below bed
- Easy bed access for inspection and cleanup

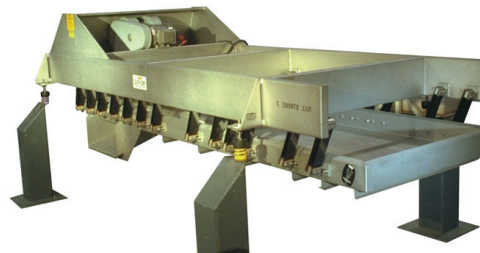

Above Bed Frame

- Ideal for distribution shakers
- Allows shortest product drops, minimizing product damage

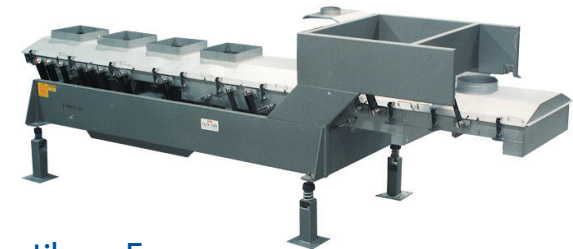

"Z" Cantilever Frame

- Ideal for spreader feed shakers
- Used with Key's corrugated long-bias discharge opening to uniformly feed blanchers, dryers, and freezers

Key Technology

150 Avery Street • Walla Walla, WA 99362 • USA

Phone: 509.529.2161 • Fax: 509.527.1331 • product.info@key.net • www.key.net



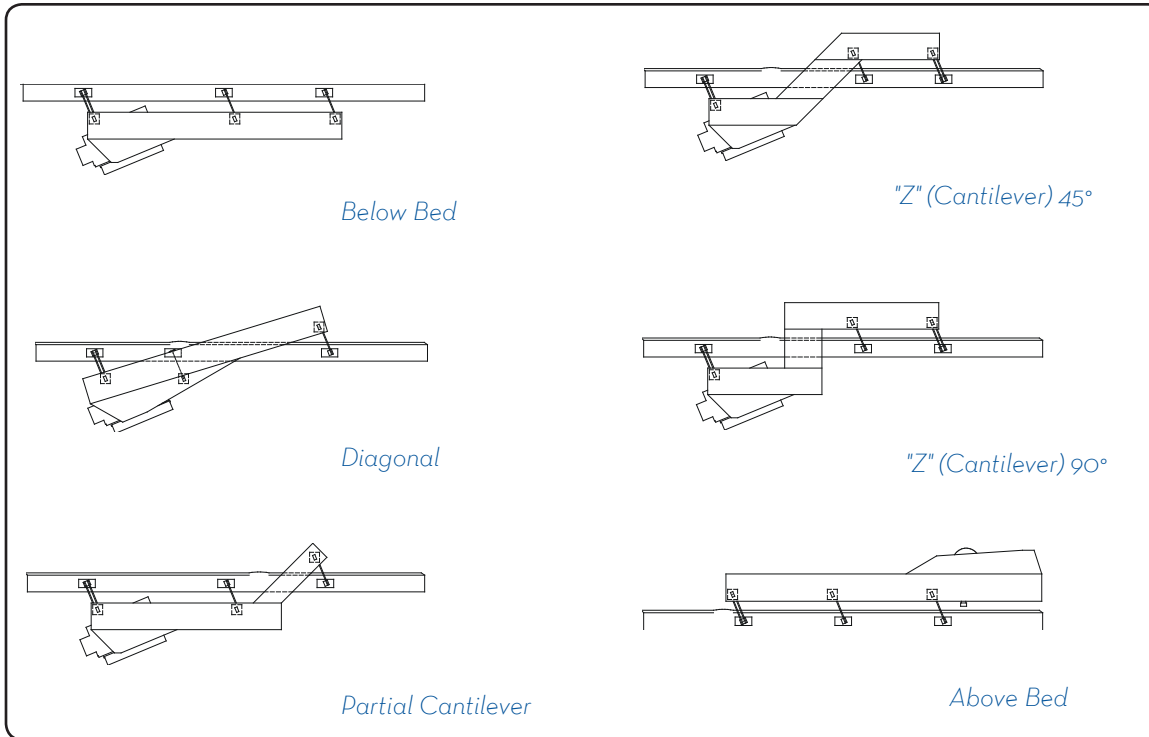

Several Representative Styles of Iso-Flo® Frames



Plate Frame

- Economical design
- Simple assembly lowers installation costs

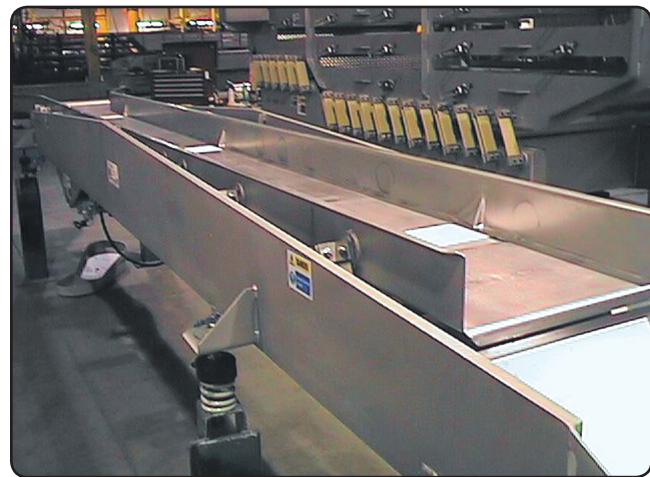

Low Profile Frame

Low Profile Frame

- Solid plate frame reduces vertical height as much as 20% compared to traditional tubular frame construction
- Designed for ease of sanitization and wipe down

Monoframe

- For Key's electric vibratory motor conveyors
- Ideal for layouts with limited space

