

Air Knife

By removing excess moisture from product, Key's [Air Knife](#) improves plant efficiency, reduces operating costs, and enhances product quality. The Air Knife features an over-line double air plenum with remote high velocity blower that provides both primary and secondary air curtains to strip moisture from product. The product momentarily stops as it flows to the primary air curtain, where it rolls, then proceeds forward for the final pass through the air curtain.

Lower Costs

- Simpler handling and storage
- Less loss from spoilage
- Reduced freezer load and associated operating costs—strips excess surface moisture from product before it enters the freeze zone, reduces buildup of ice, and requires less energy to freeze finished product

Product Quality Enhanced

- Fresh product: eliminating moisture reduces spoilage and associated costs
- IQF frozen product: eliminating moisture reduces clumping, improves consistency and quality

Additional Cooling

- Using ambient air, the Air Knife can continue the evaporative cooling process before final freeze

Easy Installation

- Air plenum unit mounts over existing line equipment and comes in various widths and styles, making it simple to enhance your process. The remote blower is connected by flexible ducting for easy placement

Sanitary and Rugged

- Side access doors at each end of the plenum permit quick sanitation. Stainless steel construction ensures long life, easy cleaning

Better Sorter Performance

- When excess water is stripped from product before sorting, optical sorters remove defects more efficiently, and reject less good product

Standard Features

- Remote blower with 4.6 m (15') of flexible ducting
- Plenum with side access doors
- All stainless steel construction

Options

- Single or double plenum in widths to fit many widths of vibrating or belt conveyor

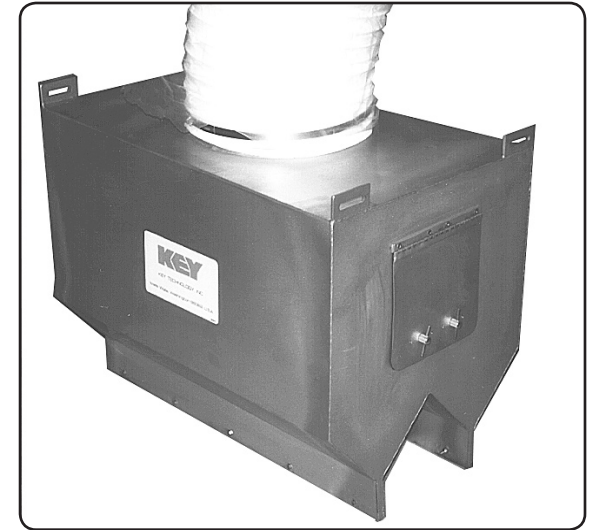

Common Product Applications

- Beans—green, wax, lima
- Berries, cranberries
- Broccoli, cauliflower
- Carrots
- Corn
- French fry strips
- Peaches, pears
- Peas—green, snap
- Vegetables

Other applications may be used on this equipment. Call Key to find out about how your product(s) may benefit from this technology or another system.

Key Technology

150 Avery Street • Walla Walla, WA 99362 • USA

Phone: 509.529.2161 • Fax: 509.527.1331 • product.info@key.net • www.key.net



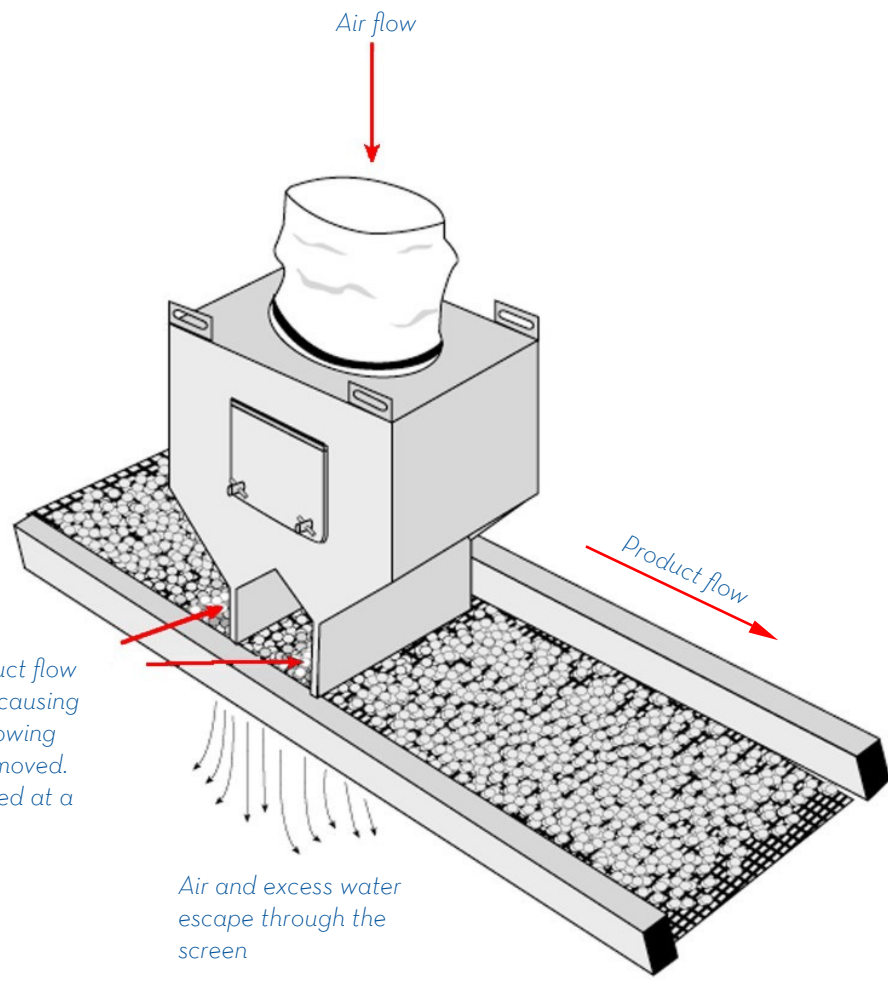

Air jets interrupt product flow at both knife stations causing product to pile up, allowing excess water to be removed. Product is then released at a metered rate.

Air and excess water escape through the screen