

# AVSealer

## Packaging and Sealing Machine

Key's AVSealer packages your fresh-cut produce reliably and consistently, while extending freshness, color, and flavor. The standard packaging machine heat seals with or without a vacuum and has an optional gas flush cycle. Simple controls provide eight adjustable user programs all in one standard offering. For solid performance in a trouble-free unit, the AVSealer is a great choice for low-to-mid-volume fresh-cut packaging needs.

The AVSealer packaging and sealing machine has a programmable range of vacuum pressures and temperatures for consistent sealing of a wide range of products including wet or dry lettuces, cut vegetables, fruit, fresh herbs and other small produce.



Loading bags is easy with the AVSealer

### Performance

- Includes vacuum and gas flush packaging methods
- 5 bags per minute per machine average
- Use with three sizes of bags from Key, or other bags
- 6 mm (1/4") wide impulse heat seal
- Built-in temperature control for consistent sealing
- CIP cycle for sanitation includes gas purge
- 240 volt supply, convertible to 110 volt

### Flexibility

- Heat seal only, or add vacuum or gas flush
- Full range of sealing temperatures for optimal sealing on a range of bag types
- Full range of vacuum pressure for optimal storage atmosphere
- Consistent low vacuum selection for leafy greens
- Gas flush settings support the range of MAP gasses for fresh-cut
- Optional bench or floor stands available for one to four units
- Seals bags up to 470 mm (18.5") wide
- 8 adjustable user programs

### Reliability

- Few moving parts
- PLC controlled
- Low-maintenance venturi vacuum system
- Easy to clean and disassemble vacuum parts
- Stainless steel and anodized aluminum construction for easy wipedown
- Spare parts kit included
- 1-year limited warranty, wear parts and labor excluded, repair/exchange at depot or replace at Key's discretion



AVSealer system on flexible rack-mounted floor stand system

Key Technology BV

Beijerdstraat 10, 4112 NE Beusichem, The Netherlands

Phone: +31 0 345-50 9900 • Fax: +31 0 345-50 1594 • keybv@key.net • www.key.net



## AVSealer Specifications

- Key part number 840360
- Maximum seal size: 470 mm (18 1/2") long x 6 mm (1/4") wide x 6 mil thick
- Cycle time: 8 to 15 seconds
- Minimum vacuum: 1% less than atmospheric pressure
- Maximum vacuum: 50% less than atmospheric pressure
- Gas flush: Single, double or triple gas purge Supports full range of compressed MAP gasses
- Control: PLC touchscreen system
- Compressed air: 7 bar @ 25 liters per minute peak (102 psi @ .88 cfm)
- Power supply capacity: 240 V, 5 A or 115 V, 10 A
- Construction: Stainless steel
- Weight: 33 kg (73 lb)

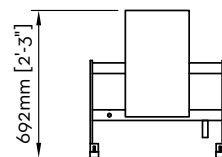
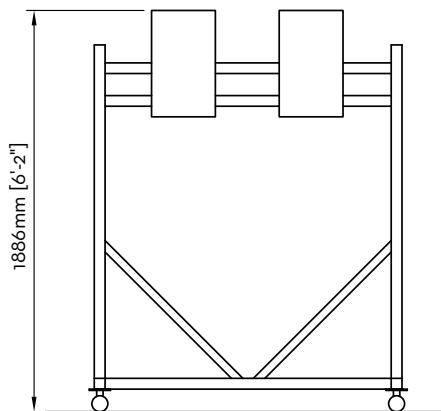
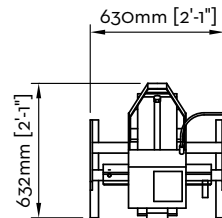
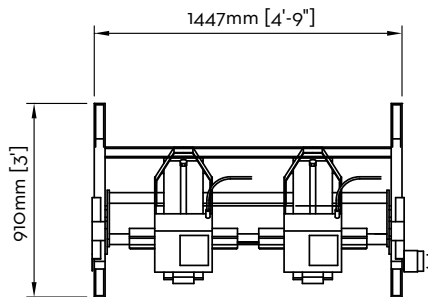

One AVSealer on a bench stand



Two AVSealers on a floor stand

## Bag Specifications

- Gauge: 60  $\mu\text{m} \pm 6 \mu\text{m}$
- Bag width: 320 mm  $\pm 5$  mm
- Bag length: (see table)
- Bags per carton: (see table)
- Oxygen transmission rate: Nominal 6000  $\pm 600$  cc/m<sup>2</sup>/day @ 23C, 0% RH
- Water transmission rate: Nominal 13  $\pm 1.5$  g/m<sup>2</sup>/day @ 38C, 90% RH
- Film color: Natural
- C.O.F. (slip): <0.25
- Sealing/melting temperature: 100C–120C
- Food contact status: All materials used are for food contact approved to AS2070 Part 1 and FDA CFR 177.1520 regulations

Part Number	Bag Length	Bags per Carton
025736	320 mm $\pm 5$ mm	1000
025737	365 mm $\pm 5$ mm	1000
025828	510 mm $\pm 5$ mm	500

**Call Key for price and delivery information or order online at [www.key.net](http://www.key.net).**



AVSealer on bench stand